

Spray Systems Bench Booths are designed for finishing small parts that may be painted at bench height. These booths provide spray area with minimal floor space. Our Bench Booths incorporate all of the same design features that our larger industrial booths are noted for.

Features & Benefits

- Booth panels pre-punched on six inch centers
- Included are exhaust fan, motor, filters, caulking, and manometer
- Quiet exhaust fan
- Easy nut and bolt assembly
- Exploded view AutoCAD assembly drawings supplied
- Meets or exceeds all OSHA, NFPA, UFC, and SCAQMD standards

Booth Construction

All panels are fabricated from corrosion resistant G-90, 18 gauge galvanized steel. Our G-90 galvanized rating has a 50% heavier zinc coating than used by many competitors. This feature allows our booths to resist corrosion, allowing your booth to last longer.

BENCH TYPE SPRAY BOOTHS

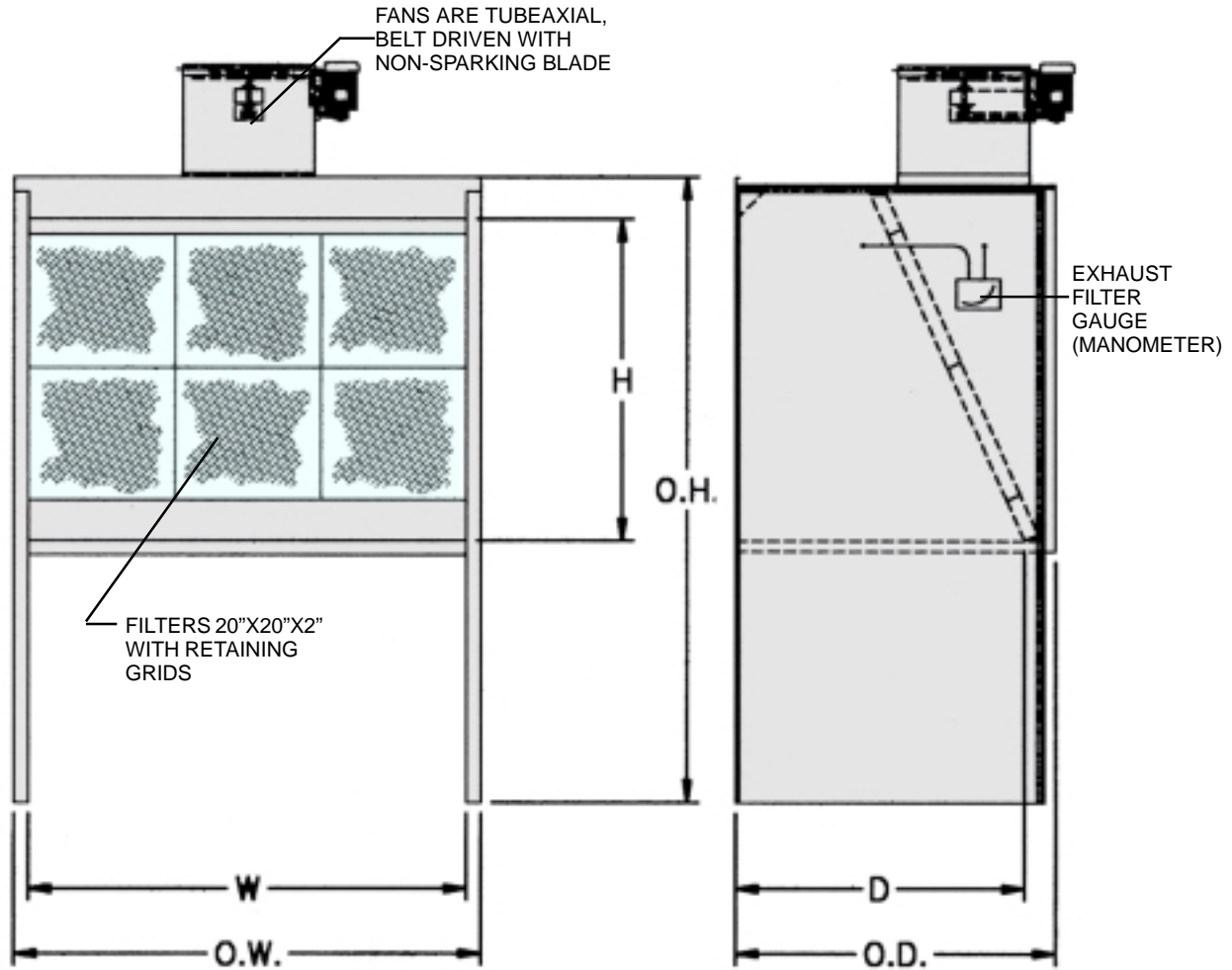

Model Number	Bench Height	Work Dimensions	Dimensions	Overall Dimensions	Exhaust Fan	Motor H.P.	Airflow SCFM @.5" S.P	Exhaust Filters (Qty)	Shipping Weight (lbs.)			
		W	H	D	OW	OH	OD					
BB-36	2'-10"	3'-0"	4'-2"	3'-6"	3'-4"	7'-2"	3'-8"	18"	1/3	1350	2	350
BB-48	2'-10"	4'-0"	4'-2"	3'-6"	4'-4"	7'-2"	3'-8"	18"	1/2	1720	4	400
BB-60	2'-10"	5'-0"	4'-2"	3'-6"	5'-4"	7'-2"	3'-8"	18"	1/2	2250	6	450
BB-72	2'-10"	6'-0"	4'-2"	4'-6"	6'-4"	7'-2"	4'-8"	18"	3/4	2750	6	550
BB-96	2'-10"	8'-0"	4'-2"	4'-6"	8'-4"	7'-2"	4'-8"	24"	3/4	3620	8	650

BENCH BOOTHS

BENCH TOP & LEG MODEL TOUCH-UP SPRAY BOOTHS

Model Number	Bench Height	Work Dimensions			Overall Dimensions			Exhaust Fan	Motor H.P.	Airflow SCFM @.5"S.P.	Exhaust Filters (Qty)	Shipping Weight (Lbs.)
		W	H	D	OW	OH	OD					
BT-2	N/A	2'-6"	2'-0"	2'-0"	2'-10"	2'-4"	2'-2"	12"	1/3	600	1	165
BT-2L	2'-10"	2'-6"	2'-0"	2'-0"	2'-10"	5'-2"	2'-2"	12"	1/3	600	1	210

* Technical specifications are subject to change at the discretion of Spray Systems, Inc.

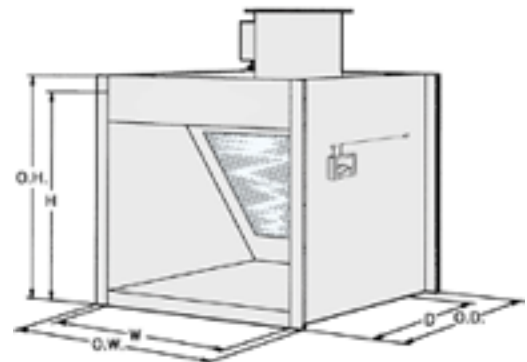
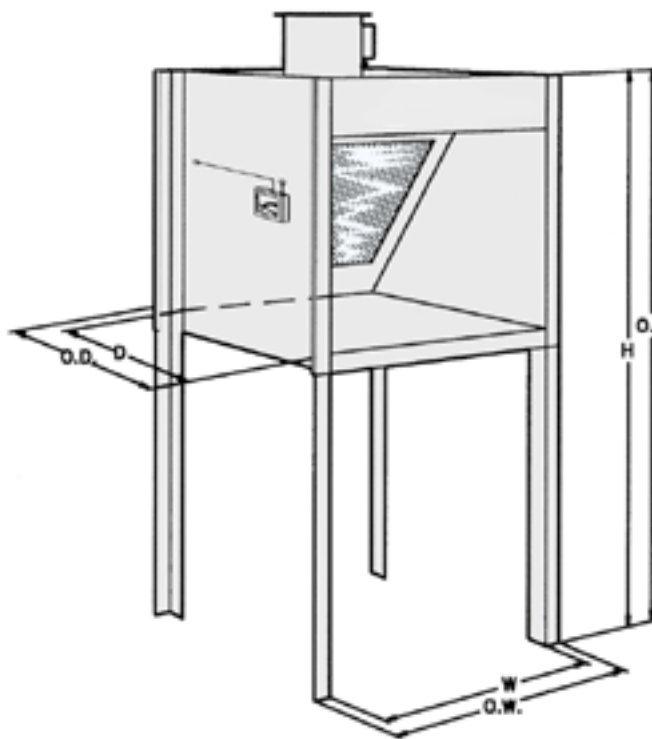

OPTIONS / ACCESSORIES

- Air Make-up Units
- Heaters / Infrared
- Specialized Filters
- Control Panels
- Exhaust Stack Components
- Doors
- Lighting

SPRAY SYSTEMS inc

WHERE CUSTOM DESIGNS ARE STANDARD

Air Make-up Units

Indirect Fired

Direct Fired

Automotive Spray Booths

Cross Draft

Down Draft

Semi-Down Draft

Bench Spray Booths

Blasting Enclosures

Control Panels

VFD Controls

Booth Controls

Conveyorized Spray Booths

Custom & Turnkey Systems

Drying Enclosures

Ductwork

Grinding Booths

Heaters

Industrial Booths

Infrared Systems

Large Equipment Booths

CentriClean™ Centrifuges

Oven Enclosures

Powder Booths

Truck Booths

Cross Draft

Down Draft

Semi-Down Draft

Water Wash Booths

Pump Style

No-Pump Style

Spray Systems, Inc. has been built on a reputation of quality. Located in Pomona, California since 1978, our 40,000 square foot facility houses state-of-the-art equipment. Our staff is dedicated to giving the customer the best in terms of service. We pride ourselves in offering the customer the best in engineering, design, quality manufacturing and materials used. We invite you to compare our products to others on the market. We are confident that when comparing Spray Systems' equipment to the competition, you'll find that we provide a superior quality product for often less investment. We believe Quality doesn't cost... It pays! In addition to the listed paint booths, we service an array of markets, which include aerospace, automotive after-market, electronics, furniture industry, large equipment, and metal finishing.

Sales and Marketing

Spray Systems, Inc. has developed an integrated distributor network promoting localized customer support and service. Our distributors are organized to focus on two distinct markets: Industrial & Automotive. A Professional Distributor Representative dedicated to customer service can then service each market.

Manufacturing

All **Spray Systems, Inc.** spray booths are manufactured using 18 gauge G-90 galvanized steel panels. Each panel is fastened together using a nut and bolt connection on six inch centers. Exhaust fans are manufactured in-house. Our design reduces noise level in the booth environment. By utilizing the latest manufacturing techniques and quality materials, we pride ourselves in offering the best product at the most cost-effective investment.

Engineering

All **Spray Systems, Inc.** spray booth assembly drawings are generated using the latest AutoCAD release. Detailed exploded view assembly drawings are included with all equipment. Each part is computer labeled with a corresponding tag number for easy installations. All of our standard booth drawings are on a CAD file. We use this information to design custom spray booths as well as sophisticated finishing systems.

**Your Local
Spray Systems
Distributor:**



SPRAY SYSTEMS inc

1363 East Grand Avenue, Pomona, California 91766
909 623-6944 Phone 909 622-6267 Fax 800 736-6944 Toll Free

www.spraysystems.com (800) 736-6944